

### Right hand side wheelhouse connections

1. Dismantle brake circuit union at the connector block on the main engine cradle spar. Prevent drips etc. as per LHS process.
2. Disconnect ABS sensor wire as per LHS process.
3. Place an oil drain tray below the oil radiator prior to disconnection of oil feed/return pipes.
4. Using a very large adjustable spanner or stilsons unscrew large pipe-nut on the side connector of the oil tank (pipe 38 in diagram).
5. Dismantle flange joint on front face of oil tank, items 50/51 in the diagram.
6. Disconnect pipe nut at the bottom of the oil radiator and remove the oil pipe. Allow oil to drain from radiator into the drain pan.
7. Disconnect fuel feed/return pipes as per LHS process.
8. Unscrew oil tank to body securing bolts (there are two).

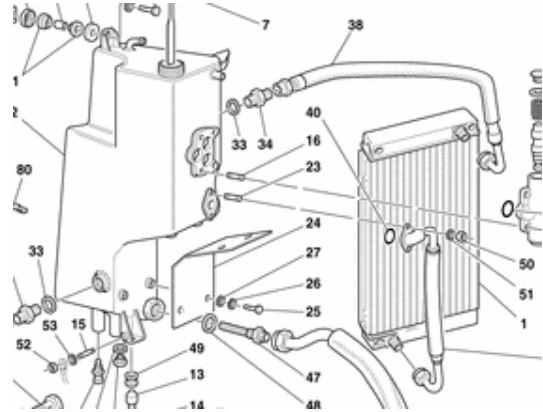

### Electrical connections

1. Disconnect electrical connectors as per checklist on page 8.
2. In addition to the electrical connectors, unscrew and remove 'P' clips for the exhaust thermocouple cables, Lambda sensors and main 12V power cables.

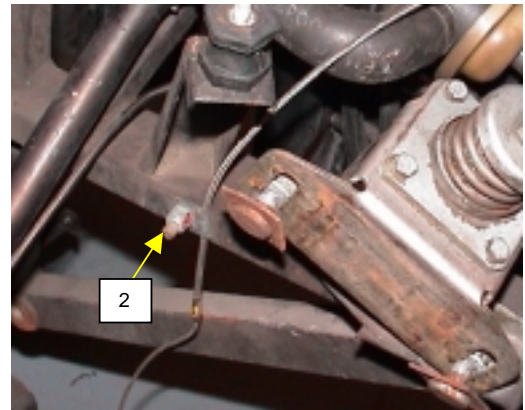

3. Unscrewing the 2x10mm nuts allows disconnection of the main 12V power cables.

### Disconnection of powertrain frame from body structure

1. The powertrain frame is secured by 20 bolts.
2. These are located as follows:
  - a. 2 groups of 6 self-aligning bolts at the base of the cradle, end of each main spar.
  - b. 2 bolts each side, directly in front of suspension strut.
  - c. 2 nuts/bolts each side, adjacent to the exhaust catalyts.

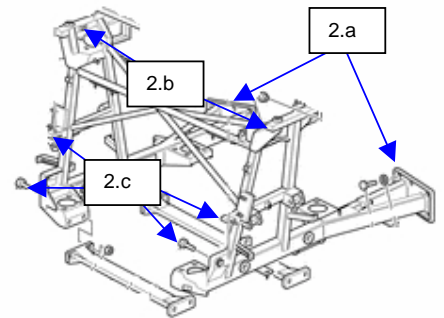

3. As a first stage, loosen all frame bolts  $\frac{1}{4}$  turn only, other than those at 2.b.
4. Place the trolley below the engine and lower the vehicle so that the weight of the powertrain is being fully borne by the trolley.
5. Position the 2 jacks under the rear jacking points.
6. Remove all the cradle bolts. Access to some of these bolts is very awkward, in particular those adjacent to the oil tank. Do not get frustrated or tempted to rush this part of the job.